

## Bourdon tube pressure gauge with switch contacts Models PGS23.1x0, stainless steel version

WIKA data sheet PV 22.02



**switchGAUGE**

### Applications

- Control and regulation of industrial processes
- Monitoring of plants and switching of electric circuits
- For gaseous and liquid aggressive media that are not highly viscous or crystallising, also in aggressive ambience
- Process industry: Chemical, petrochemical, power plants, mining, on- and offshore, environmental technology, machine building and general plant construction

### Special features

- High reliability and long service life
- Up to 4 switch contacts per instrument
- Also available with liquid-filled case for high dynamic pressure loads or vibrations
- Gauges with inductive contacts for use in hazardous areas with ATEX approval
- Gauges with electronic contact for PLC applications
- Gauges in safety version S3 (S)



**Bourdon tube pressure gauge model PGS23.100**

### Description

Wherever the process pressure has to be indicated locally, and, at the same time, circuits are to be made or broken, the model PGS23.1x0 switchGAUGE can be used.

Switch contacts (electrical alarm contacts) make or break an electric control circuit dependent upon the position of the instrument pointer. The switch contacts are adjustable over the full extent of the scale range (see DIN 16085), and are mounted predominantly below the dial, though also partly on top of the dial. The instrument pointer (actual value pointer) moves freely across the entire scale range, independent of the setting.

The set pointer can be adjusted using a removable adjustment key in the window.

Switch contacts consisting of several contacts can also be set to a single set point. Contact actuation is made when the actual value pointer travels beyond or below the desired set point.

The pressure gauge is manufactured in accordance with DIN 16085 and fulfils all requirements of the relevant standards (EN 837-1) and regulations for the on-site display of the working pressure of pressure vessels. As switch contacts magnetic snap-action contacts, reed switches, inductive contacts - for requirements to ATEX - or electronic contacts for triggering a PLC are available. For further information on the different switch contacts please see data sheet AC 08.01.

## Standard version

### Nominal size in mm

100, 160

### Accuracy class

1.0

### Scale ranges

0 ... 0.6 to 0 ... 1600 bar

or all other equivalent vacuum or combined pressure and vacuum ranges

### Pressure limitation

Steady: Full scale value

Fluctuating: 0.9 x full scale value

Short time: 1.3 x full scale value

### Permissible temperature

Ambient: -20 ... +60 °C for gauges without liquid filling and gauges with silicone oil filling

Medium: +200 °C maximum without liquid filling

+100 °C maximum with liquid filling

### Temperature effect

When the temperature of the measuring system deviates from the reference temperature (+20 °C):

Max.  $\pm 0.4\%$  / 10 K of full scale value

### Process connection

Stainless steel 316L,

lower mount (LM) or lower back mount (LBM)

G ½ B (male), 22 mm flats

### Pressure element

Stainless steel 316L

< 100 bar: C-type

≥ 100 bar: Helical type

### Movement

Stainless steel

### Dial

Aluminium, white, black lettering

### Pointer

Instrument pointer: Aluminium, black

Set pointer: red

### Case

Stainless steel, scale ranges ≤ 0 ... 16 bar with compensating valve to vent case, with blow-out device in case back

With safety version: With solid baffle wall (Solidfront) and blow-out back, hermetically sealed, with internal pressure compensation

### Window

Laminated safety glass

### Bezel ring

Cam ring (bayonet type), stainless steel

### Electrical connection

Terminal box

### Ingress protection

IP 65 per EN 60529 / IEC 529

## Switch contacts

### Magnetic snap-action contact model 821

- No control unit and no extra power supply required
- Direct switching up to 230 V
- Up to 4 switch contacts per measuring instrument

### Inductive contact model 831

- Long service life due to non-contact sensor
- Additional control unit required
- With corresponding control unit suitable for use in zone 1 / 21 (2 GD) hazardous areas
- Low effect on the indication accuracy
- Fail-safe switching at high switching rates
- Insensitive to corrosion
- Up to 3 switch contacts per measuring instrument

### Electronic contact model 830 E

- For direct triggering of a programmable logic controller (PLC)
- No additional control unit required
- Long service life due to non-contact sensor
- Low effect on the indication accuracy
- Fail-safe switching at high switching rates
- Insensitive to corrosion
- Up to 3 switch contacts per measuring instrument

### Reed switch model 851

- No control unit and no extra power supply required
- Direct switching up to 250 V, 1 A
- Also suitable for direct triggering of a programmable logic controller (PLC)
- Free from wear as without contact
- Up to two change-over contacts per measuring instrument

### Switching function

The switching function of the switch is indicated by function index 1, 2 or 3.

Model 8XX.1: Contact makes (clockwise pointer motion)

Model 8XX.2: Contact breaks (clockwise pointer motion)

Models 821.3 and 851.3: Change over; one contact breaks and one contact makes simultaneously when pointer reaches set point

**For further information please see data sheet AC 08.01, electrical switch contacts**

## Options

- Other process connection
- Liquid filling (observe: With safety version only lower mount)
- Inductive contacts also in safety version
- Dual scale
- Panel mounting flange, polished stainless steel
- Surface mounting flange, stainless steel
- Surface mounting lugs on the back, stainless steel (safety version)
- SIL2 approval (safety version)
- Pressure switch per VdTÜV code of practice 100

# Dimensions in mm

## switchGAUGE model PGS23.100

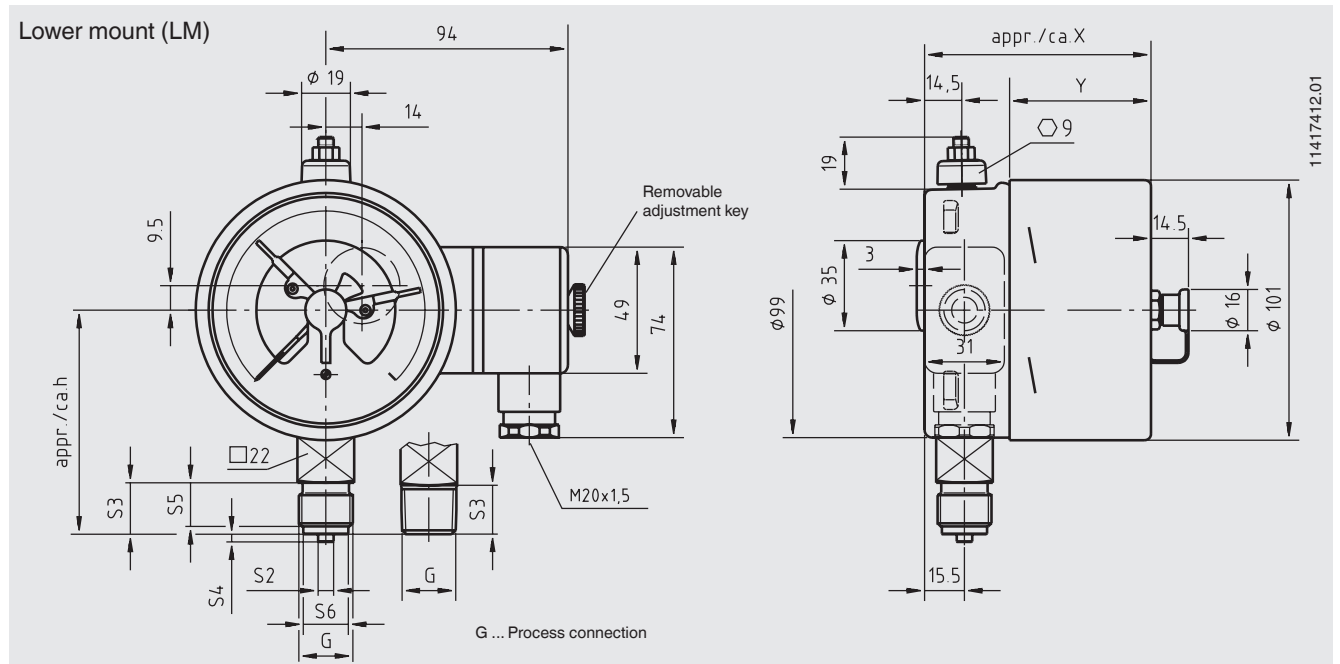

Type of contact	Dimensions in mm	
	X	Y
Single or double contact	88	55
Double contact (SPDT)	113	80
Triple contact	96	63
Quadruple contact	113	80

Process connection	Dimensions in mm					
	h ± 1	S2	S3	S4	S5	S6
G ½ B	87	6	20	3	17	17.5
G ¼ B	80	5	13	2	11	9.5
G 3/8 B	83	5.5	16	3	13	13
½ NPT	86	-	19	-	-	-

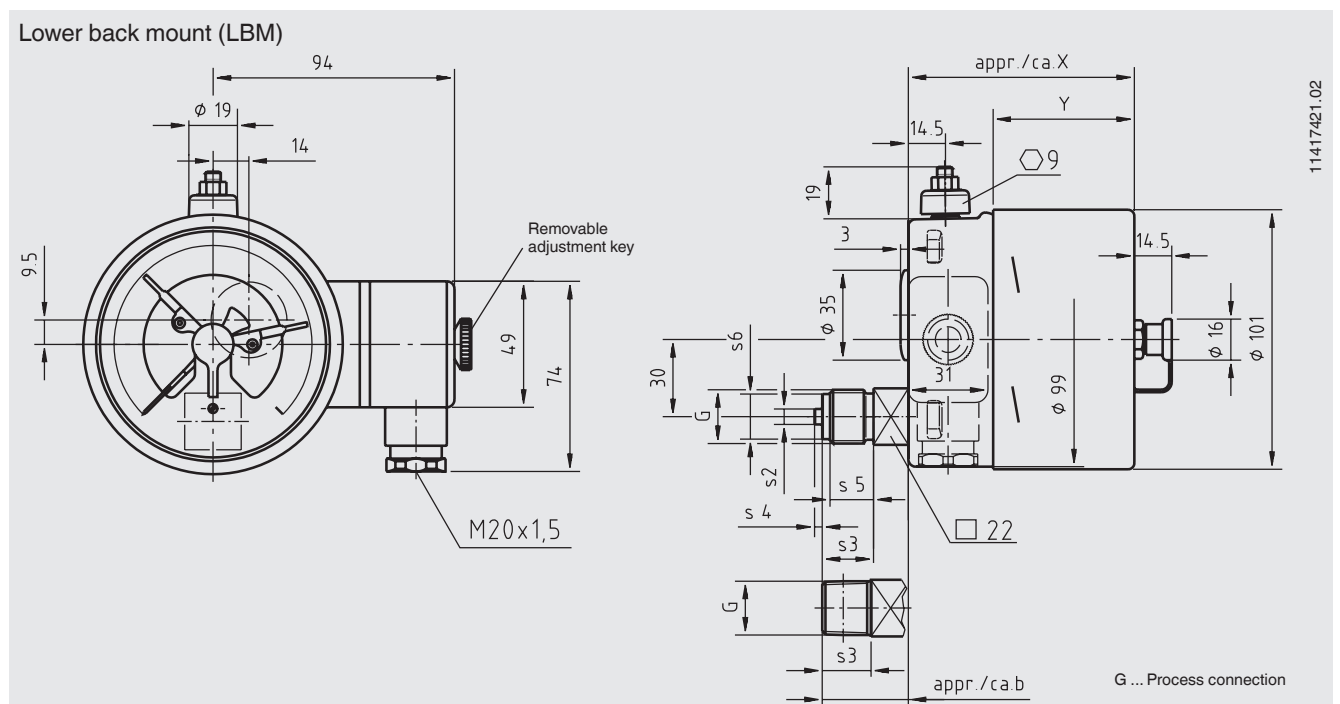

Type of contact	Dimensions in mm	
	X	Y
Single or double contact	88	55
Double contact (SPDT)	113	80
Triple contact	96	63
Quadruple contact	113	80

Process connection	Dimensions in mm					
	b	S2	S3	S4	S5	S6
G ½ B	33.5	6	20	3	17	17.5
G ¼ B	26.5	5	13	2	11	9.5
G 3/8 B	29.5	5.5	16	3	14	13
½ NPT	32.5	-	19	-	-	-

switchGAUGE model PGS23.100 (safety version)

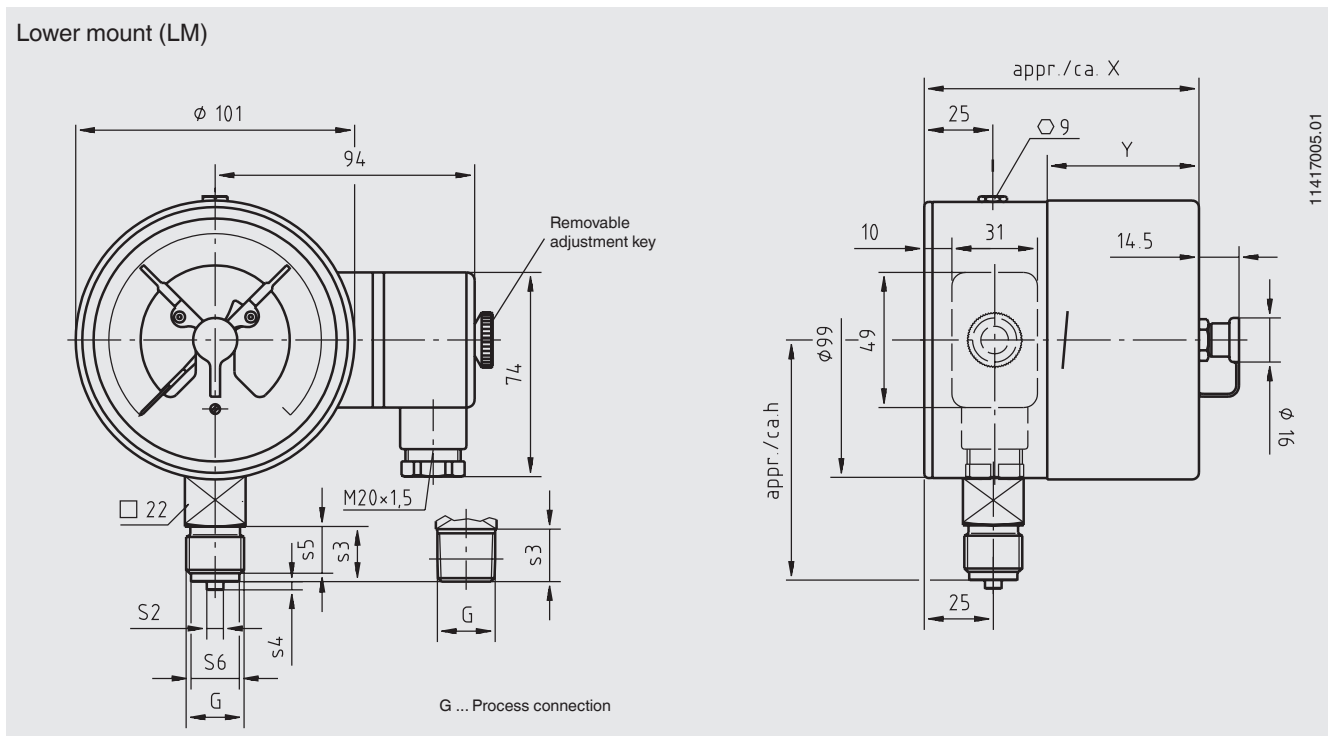

Type of contact	Dimensions in mm	
	X	Y
Single or double contact	97	55
Double contact (SPDT)	122	80
Triple contact	105	63
Quadruple contact	122	80

Process connection	Dimensions in mm					
	$h \pm 1$	S2	S3	S4	S5	S6
<b>G 1/2 B</b>	87	6	20	3	17	17.5
<b>G 1/4 B</b>	80	5	13	2	11	9.5
<b>G 3/8 B</b>	83	5.5	16	3	14	13
<b>1/2 NPT</b>	86	-	19	-	-	-

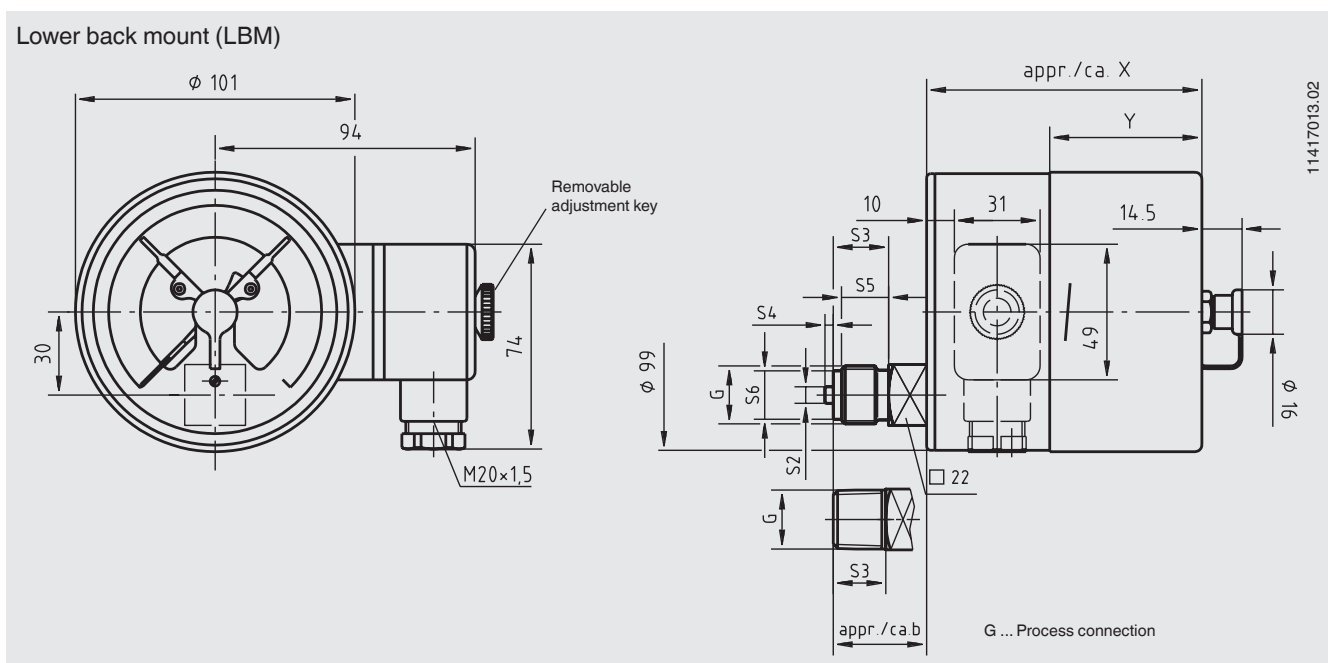

Type of contact	Dimensions in mm	
	X	Y
Single or double contact	97	55
Double contact (SPDT)	122	80
Triple contact	105	63
Quadruple contact	122	80

Process connection	Dimensions in mm					
	b	S2	S3	S4	S5	S6
<b>G 1/2 B</b>	33.5	6	20	3	17	17.5
<b>G 1/4 B</b>	26.5	5	13	2	11	9.5
<b>G 3/8 B</b>	29.5	5.5	16	3	14	13
<b>1/2 NPT</b>	32.5	-	19	-	-	-

switchGAUGE model PGS23.160

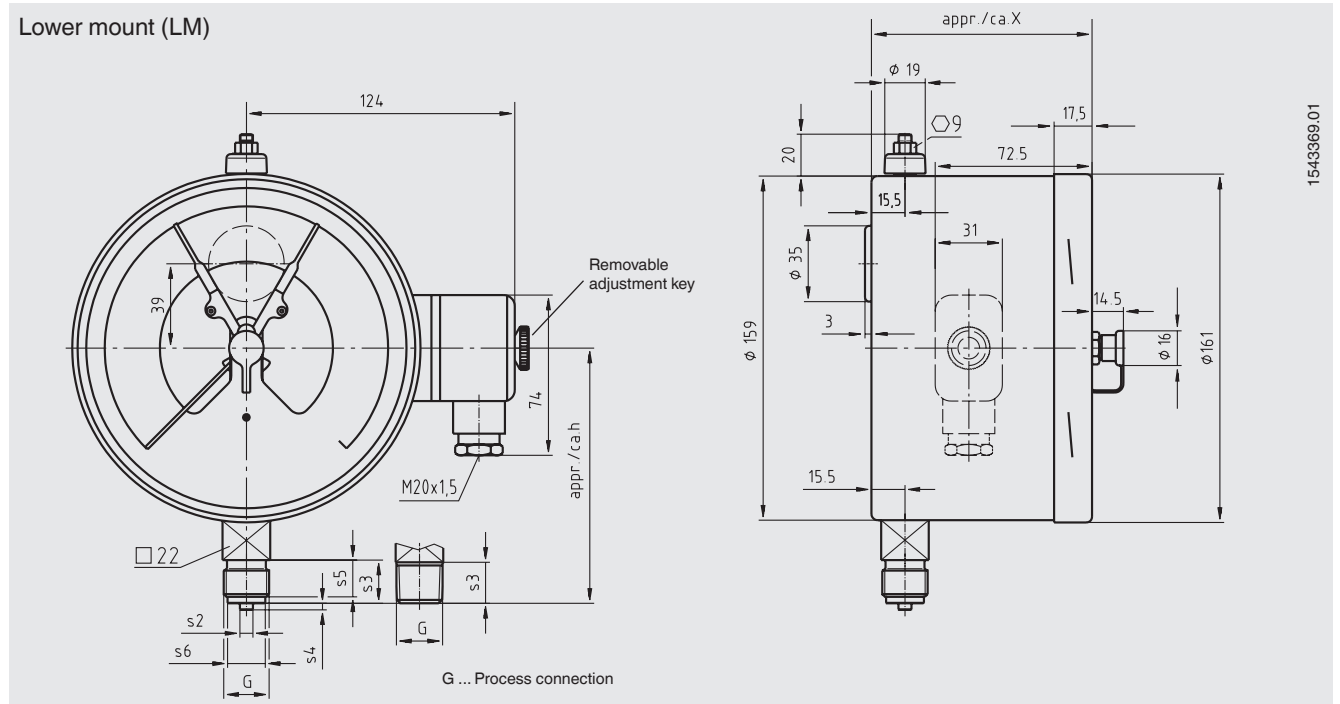

1543369.01

Type of contact	Dimensions X in mm
Single, double or triple contact	102 <sup>1)</sup>
Double contact (SPDT), quadruple contact	116 <sup>1)</sup>

1) Plus 14 mm with pressure ranges  $\geq 0 \dots 100$  bar

Process connection	h $\pm 1$	S2	S3	S4	S5	S6
<b>G 1/2 B</b>	118	6	20	3	17	17.5
<b>G 1/4 B</b>	111	5	13	2	11	9.5
<b>G 3/8 B</b>	114	5.5	16	3	14	13
<b>1/2 NPT</b>	117	-	19	-	-	-

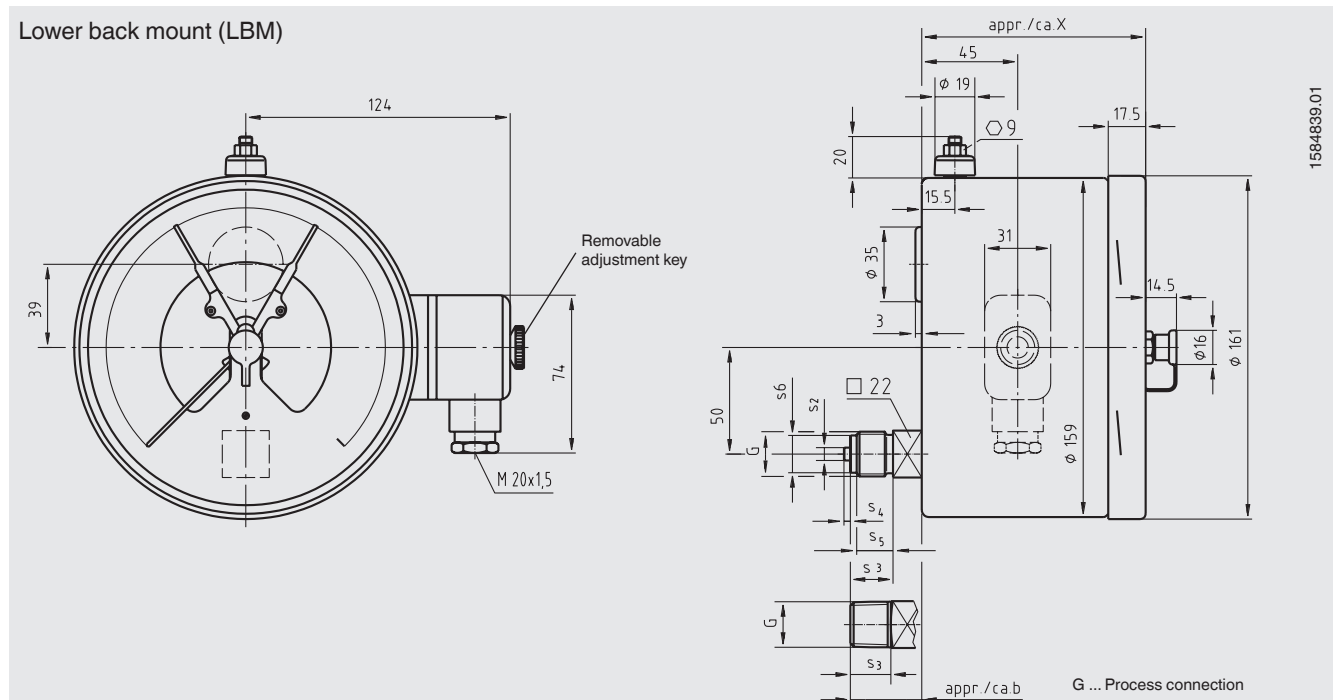

1564839.01

Type of contact	Dimensions X in mm
Single, double or triple contact	105
Quadruple contact	119

Process connection	b	S2	S3	S4	S5	S6
<b>G 1/2 B</b>	33.5	6	20	3	17	17.5
<b>G 1/4 B</b>	26.5	5	13	2	11	9.5
<b>G 3/8 B</b>	29.5	5.5	16	3	14	13
<b>1/2 NPT</b>	32.5	-	19	-	-	-

**switchGAUGE model PGS23.160 (safety version)**

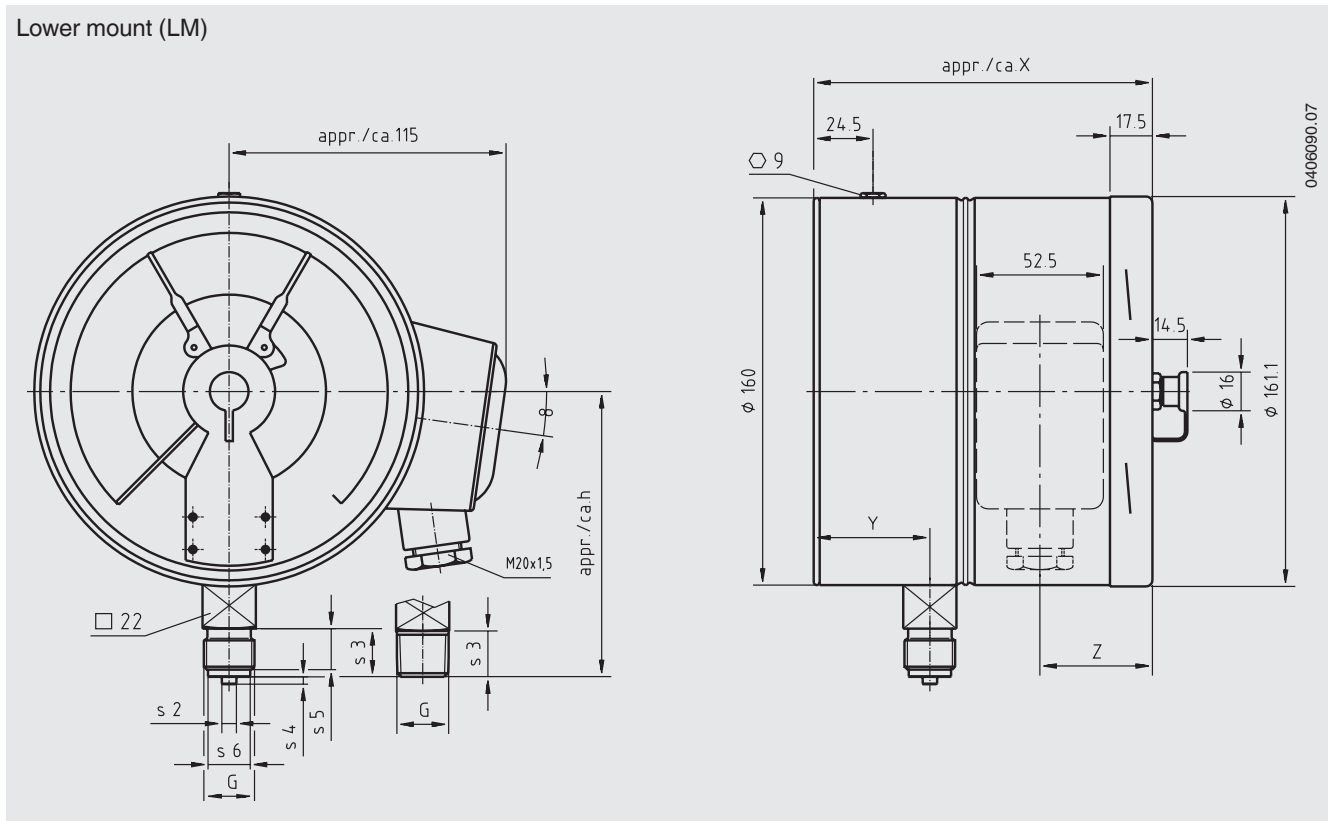

Type of contact	Dimensions in mm		
	X	Y	Z
Single or double contact	141	30.5 <sup>1)</sup>	48
Triple contact	153.5	30.5 <sup>1)</sup>	60.5

Process connection	Dimensions in mm					
	h ± 1	S2	S3	S4	S5	S6
<b>G ½ B</b>	118	6	20	3	17	17.5
<b>½ NPT</b>	117	-	19	-	-	-
<b>M20 x 1.5</b>	118	6	20	3	17	17.5

1) Plus 17 mm with pressure ranges ≤ 0 ... 60 bar

**Ordering information**

Model / Nominal size / Type of contact and switching function / Scale range / Connection size / Connection location / Options

© 2008 WIKA Alexander Wiegand SE & Co. KG, all rights reserved.  
The specifications given in this document represent the state of engineering at the time of publishing.  
We reserve the right to make modifications to the specifications and materials.



**WIKAI Alexander Wiegand SE & Co. KG**  
Alexander-Wiegand-Straße 30  
63911 Klingenberg/Germany  
Tel. (+49) 9372/132-0  
Fax (+49) 9372/132-406  
E-mail info@wika.de  
www.wika.de